

REVISIONS				
ZONE	REV.	DESCRIPTION	DATE	APPROVED
	-	INITIAL RELEASE	12/5/24	AJ.M.

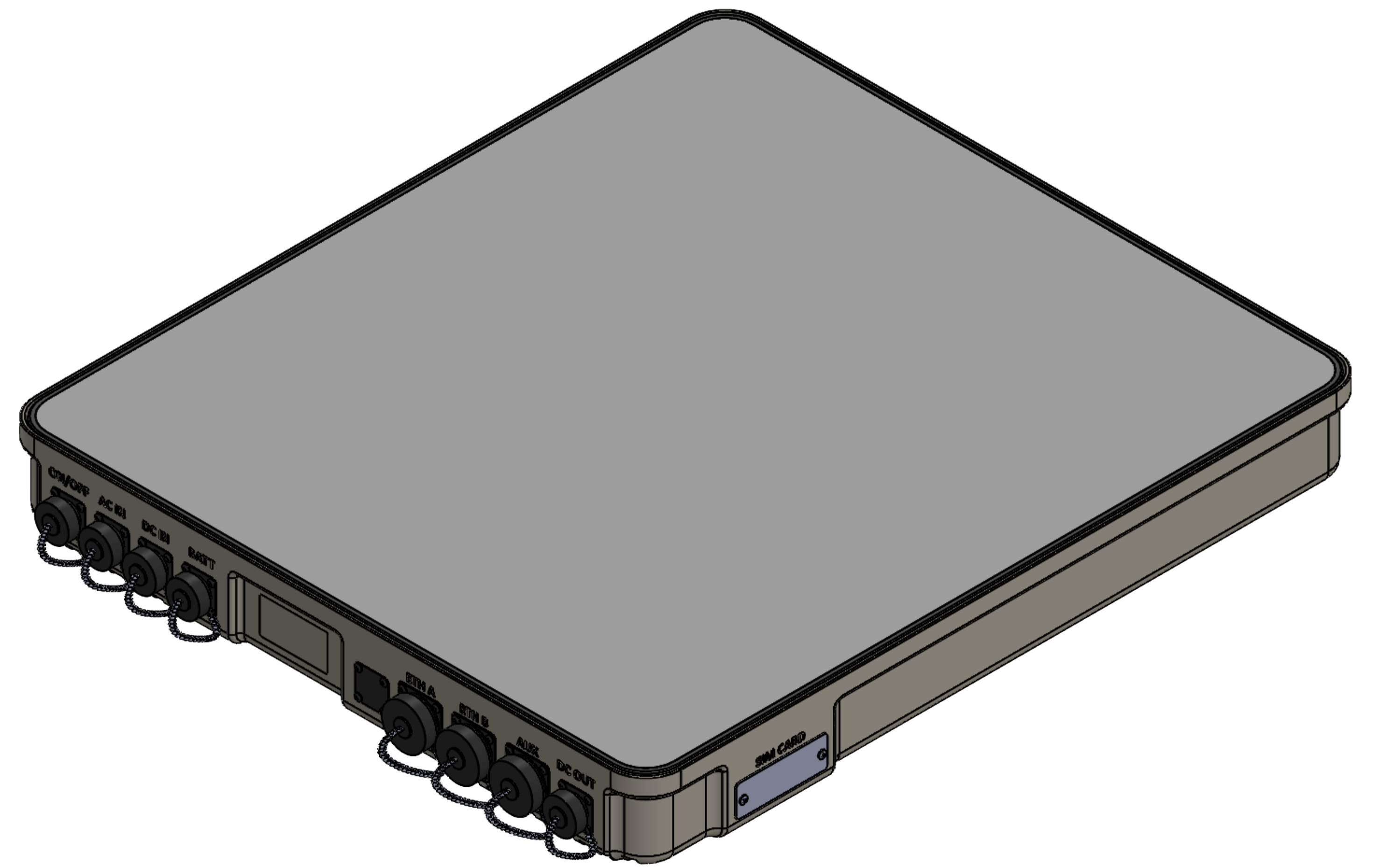
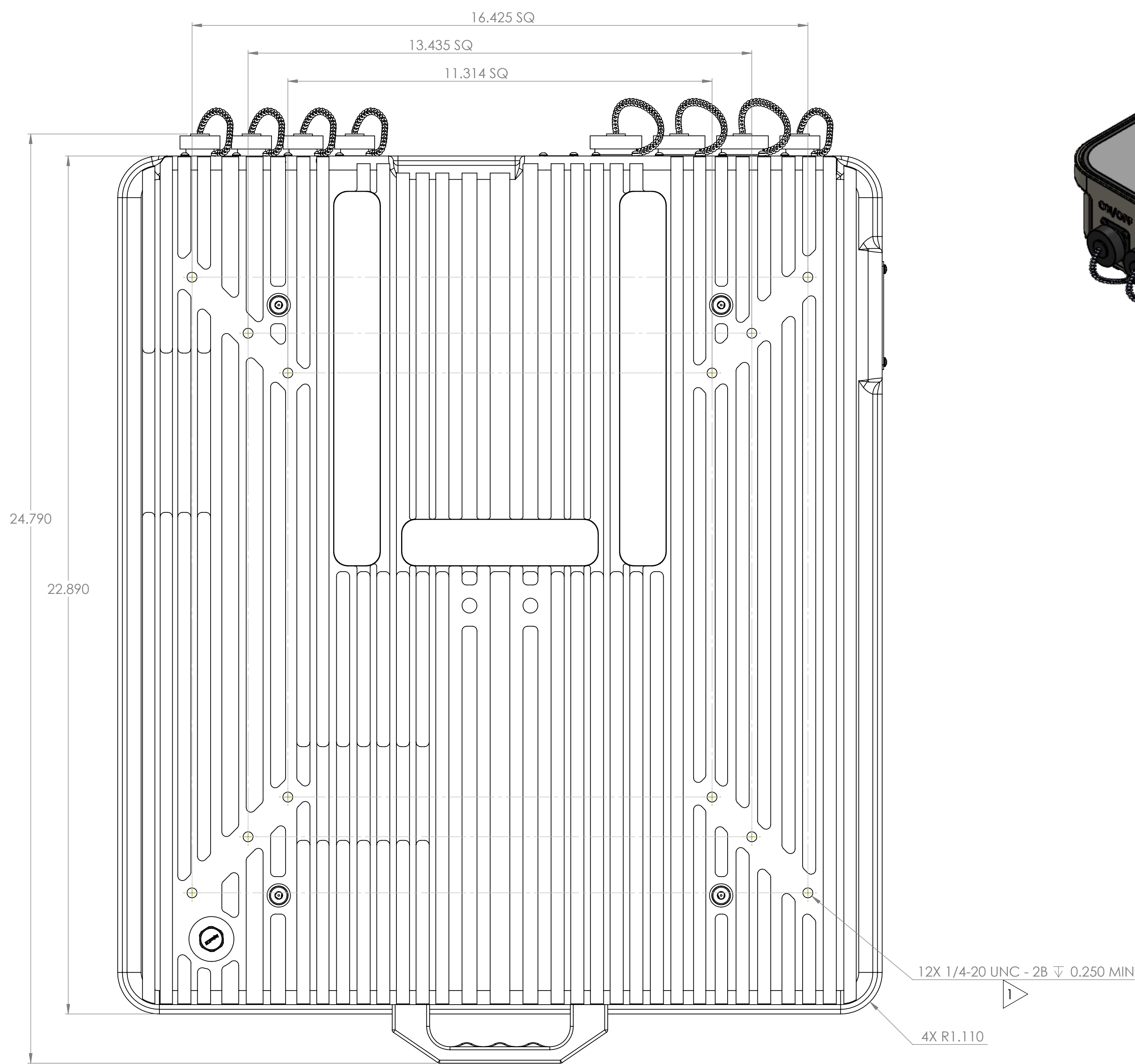
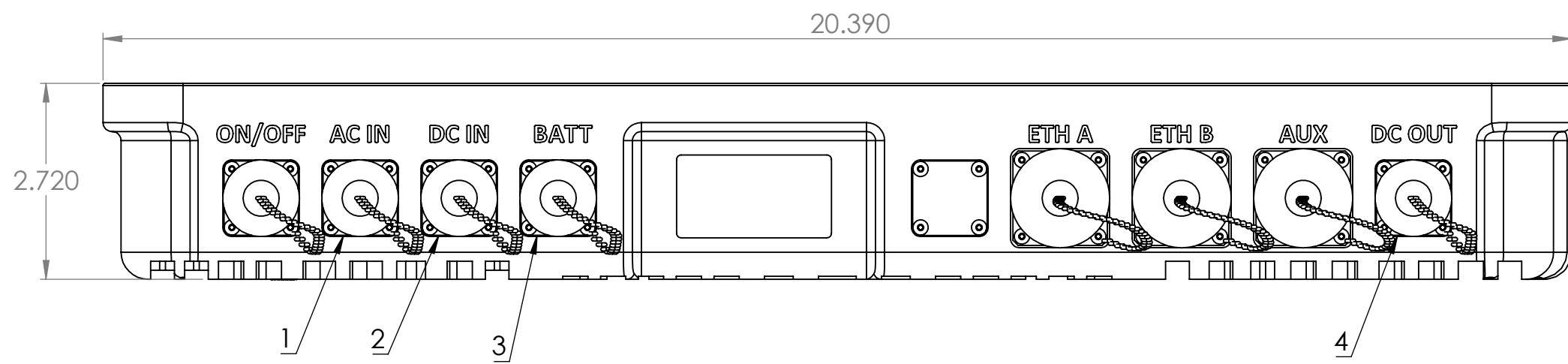

ISO VIEW FOR REFERENCE ONLY

CONNECTOR INTERFACE TABLE				
FN	DESCRIPTION	MANUFACTURER PN	MATING CONNECTOR PN	VENDOR
1	AC IN	PT02E-12-3P(025)	PT06E-12-3S(470)	AMPHENOL
2	DC IN	PT02E-12-10P(025)	PT06E-12-10S(470)	AMPHENOL
3	BATT	PT02E-12-8P(025)	PT06E-12-8S(470)	AMPHENOL
4	DC OUT	PT02E-12-4S (025)	PT06E-12-4P (470)	AMPHENOL

NOTES:
 MAX TORQUE = 55 IN-LBS

DO NOT SCALE DRAWING		3RD ANGLE PROJECTION			
INTERPRET PER ASME Y14.5M-2009		MATERIAL:	NAME	DATE	COPASAT TITLE: STORM V3 STORMSHIELD 5G ICD
DIMENSIONS ARE IN INCHES UNLESS OTHERWISE SPECIFIED		NA	AJ.M.	12/5/24	
TOLERANCES:		FINISH:	ENG APPR.		
FRACTIONAL: ±1/16" ANGULAR: ±1° ONE PLACE DECIMAL: ±0.1 TWO PLACE DECIMAL: ±0.01 THREE PLACE DECIMAL: ±0.005		PROPRIETARY AND CONFIDENTIAL THE INFORMATION CONTAINED IN THIS DRAWING IS THE SOLE PROPERTY OF COPASAT. ANY REPRODUCTION IN PART OR AS A WHOLE WITHOUT THE WRITTEN PERMISSION OF COPASAT IS PROHIBITED.		SIZE D	PART. NO. CS-52-010500
		SCALE: 1:2		WEIGHT ~32.1LBS	REV - SHEET 1 OF 1